



Integrating Biomass to Produce Heat and Power at Ethanol Plants

Matt De Kam

deka0017@umn.edu, (612) 418-4154

Vance Morey

Professor, Bioproducts and Biosystems Engineering. University of Minnesota.

Doug Tiffany

Research Fellow, Applied Economics. University of Minnesota.

Project Partners:



Overview

- n Project background
 - n Modeling methods
 - n Results
 - n Technical conclusions
-

Motivations for Using Biomass

- n Potential to improve Renewable Energy Ratio
 - q Defined as: $\text{Energy Out} / \text{Fossil Energy In}$
 - n Potential for **2.4** to **4.8** Renewable Energy Ratio depending on conversion efficiency (Morey et al. 2006)
 - n Can generate reliable renewable power for the grid
 - n Lower the overall greenhouse gas emissions from ethanol production
-

ASPEN Plus Ethanol Plant Model

- n USDA ARS developed model
 - n 40MMgal/year baseline
 - q Scaled up to 50 MMgal/year for this analysis
 - q All the data in this presentation are for 50 MMgal/yr facilities
 - n Used this model to understand the ethanol process and its energy requirements
 - n Heat and power generation systems are based upon this model
 - q Process steam is at 50 psig
-

Conventional Dry Grind Ethanol

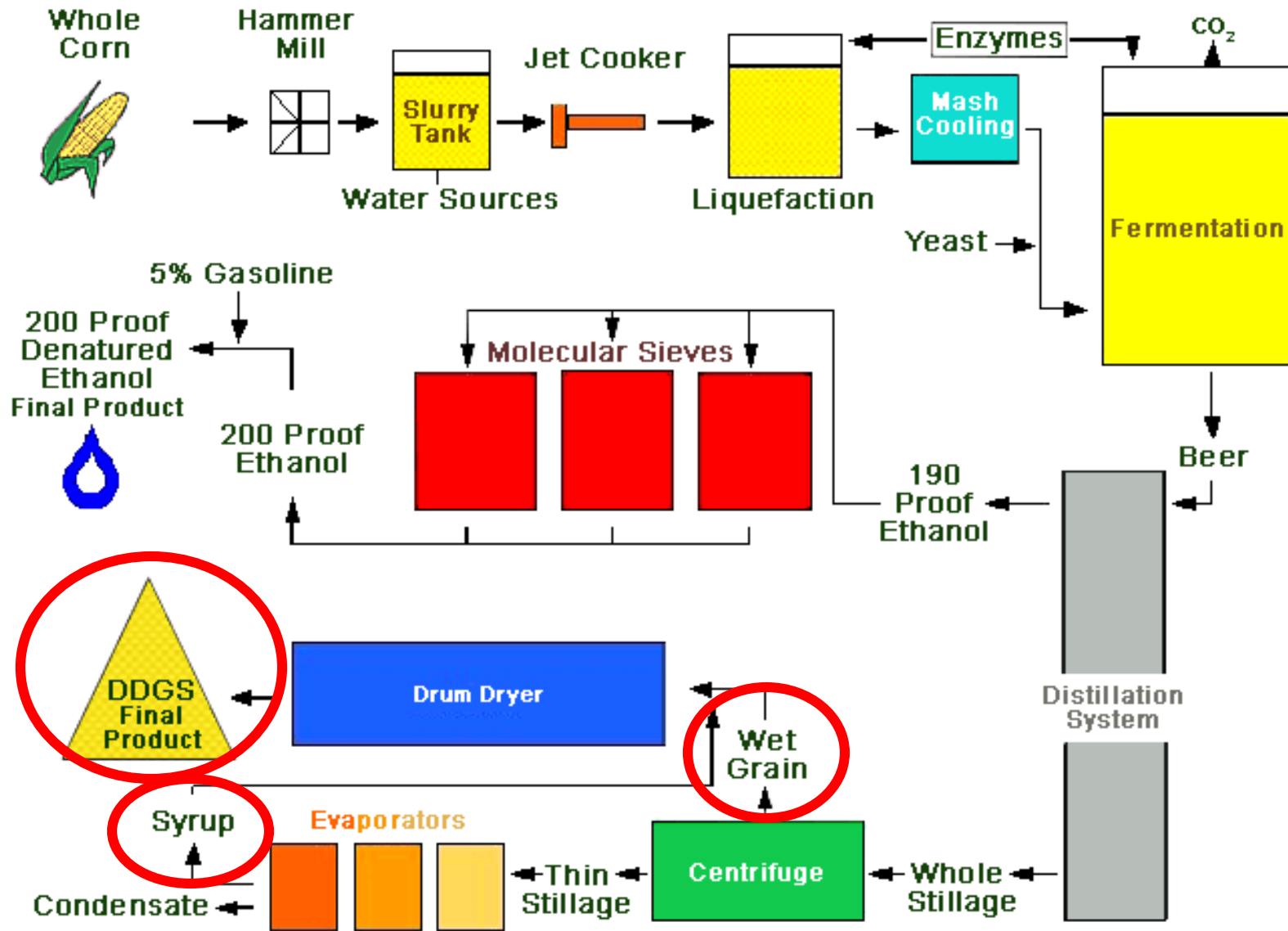

Emissions Modeling

- n RMT: Computational Fluid Dynamics
 - q Predictive modeling of emissions
 - q The Aspen Plus models were based upon these emissions estimates and data from the literature

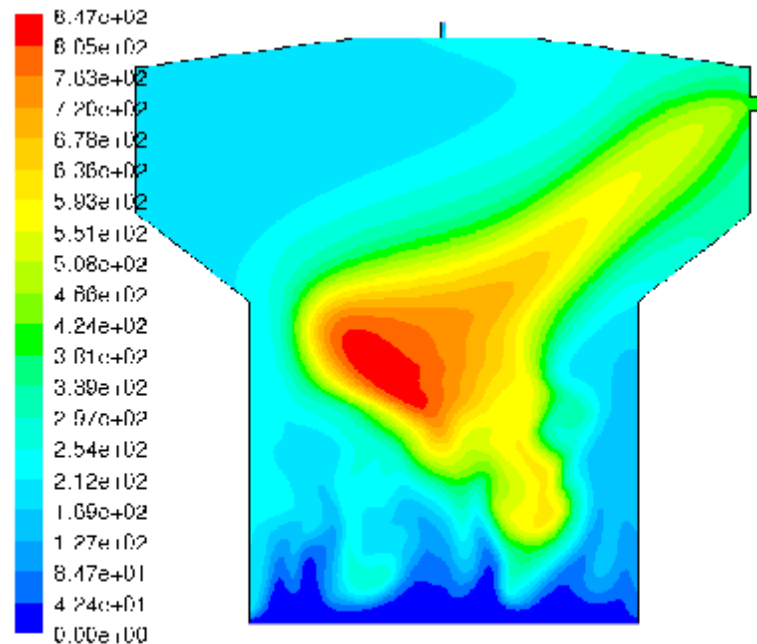

Definition of Technology Combinations

n Thermal conversion

q Fluidized bed combustion

- n Able to handle fuels with high moisture
- n Some flexibility of fuel sizing

q Fluidized bed gasification

- n Lower reaction temperatures
 - n Greater opportunity to control some types of emissions
-

Definition of Technology Combinations

n Co-product Drying

- q Natural gas fired, direct dryers are typical
 - q Steam tube, indirect dryers
 - n Commonly used for solid fuel systems
 - n Lower volume of dryer exhaust
-

Definition of Technology Combinations

n Emissions Control

- q Dryer Volatile Organic Compounds (VOC)
 - n Route dryer exhaust through combustion unit
 - q Particulate Matter
 - n Cyclones
 - n Baghouse
 - q SO_x emissions
 - n Limestone sorbent bed material
 - n Flue Gas Desulfurization (FGD) semi-dry scrubbing
 - q NO_x emissions
 - n Selective Non-Catalytic Reduction (SNCR)
 - q HCL emissions
 - n Semi-dry scrubbing
-

Definition of Technology Combinations

n Electricity Generation

q Back-Pressure Turbine

- n Constant steam pressure at outlet
- n Should use all outlet steam for process needs

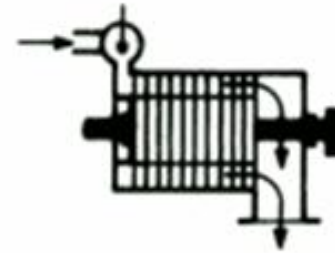

q Extraction Turbine

- n Extract Steam at constant pressure for process
- n Condense excess steam at low pressure

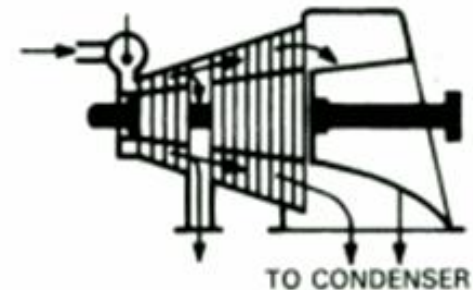

Definition of Technology Combinations

- n Levels of electricity generation
 - q Level 1: Process Heat
 - n Produce steam for process needs only
 - n No electricity generated
 - q Level 2: CHP
 - n Produce steam to drive a backpressure turbine
 - n All turbine exhaust steam is used for process needs at 50 psig
 - q Level 3: CHP + Grid
 - n Produce steam to drive an extraction turbine
 - n Process steam is extracted at intermediate pressure (50 psig)
 - n Excess steam is condensed at low pressure
 - n Heat rate is limited by the total fuel energy available in the co-products at the plant
-

Combustion of Corn Stover, Level 1: Process Heat

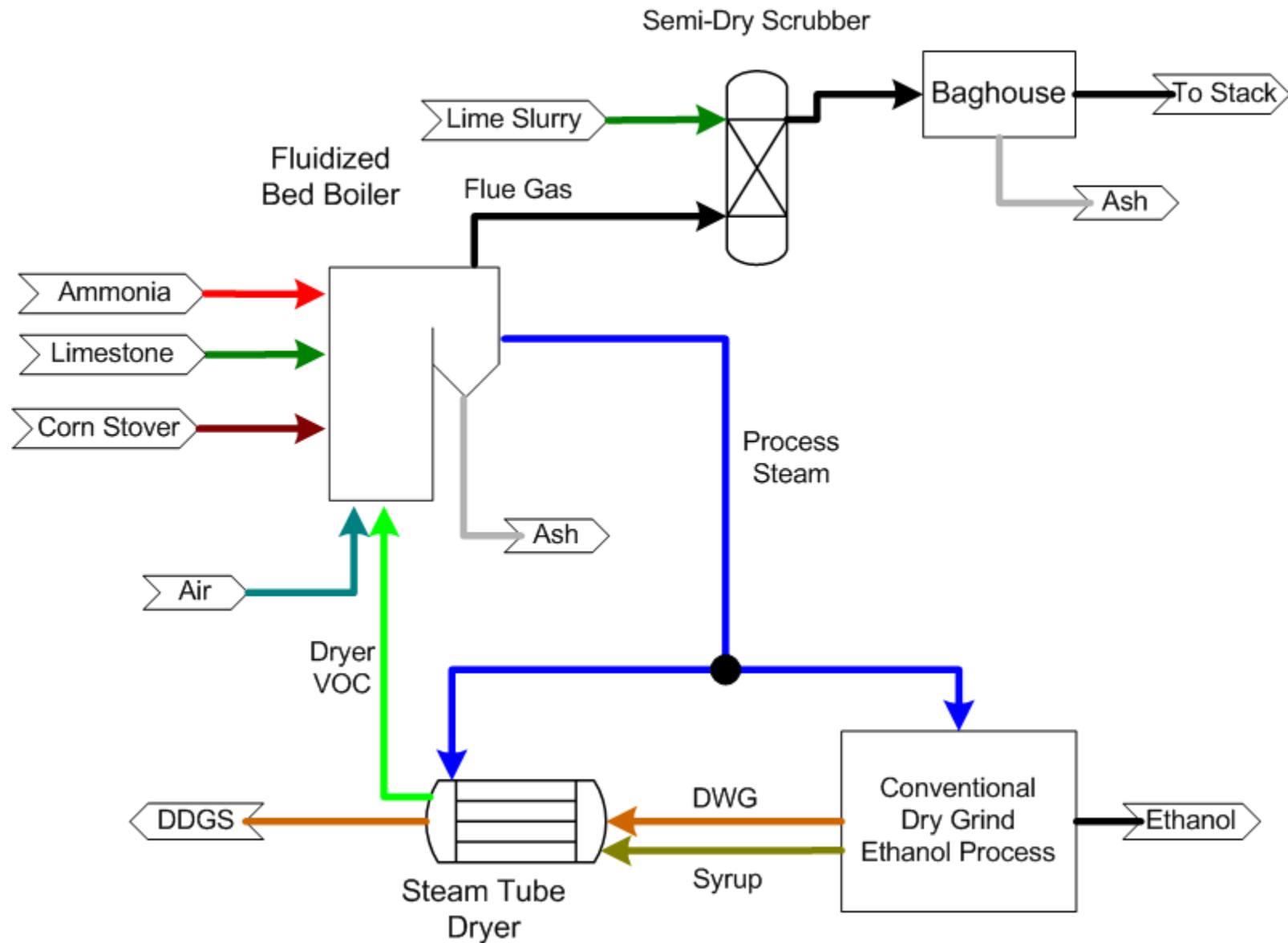

Combustion of Corn Stover, Level 2: CHP

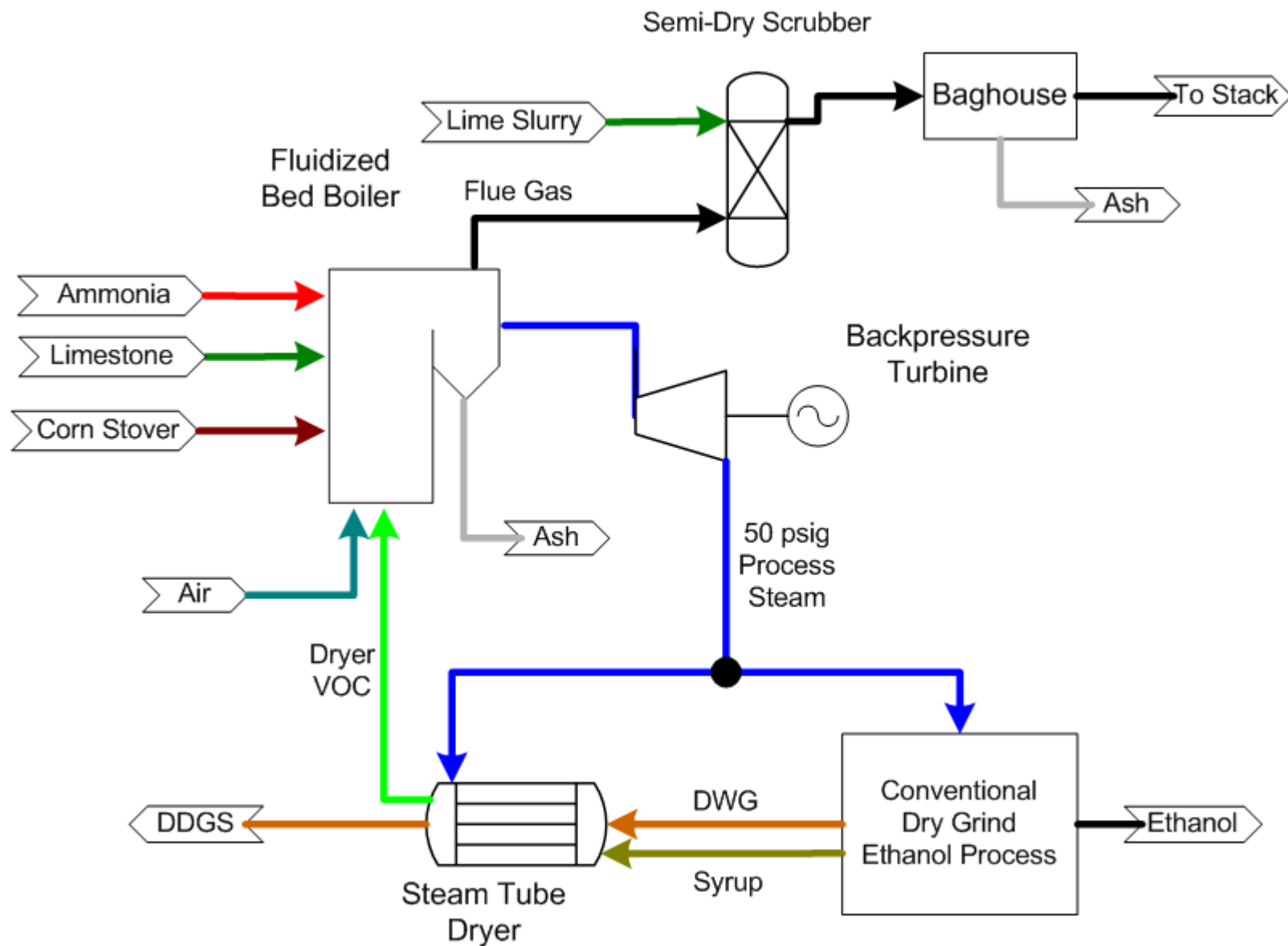

Combustion of Corn Stover, Level 3: CHP + Grid

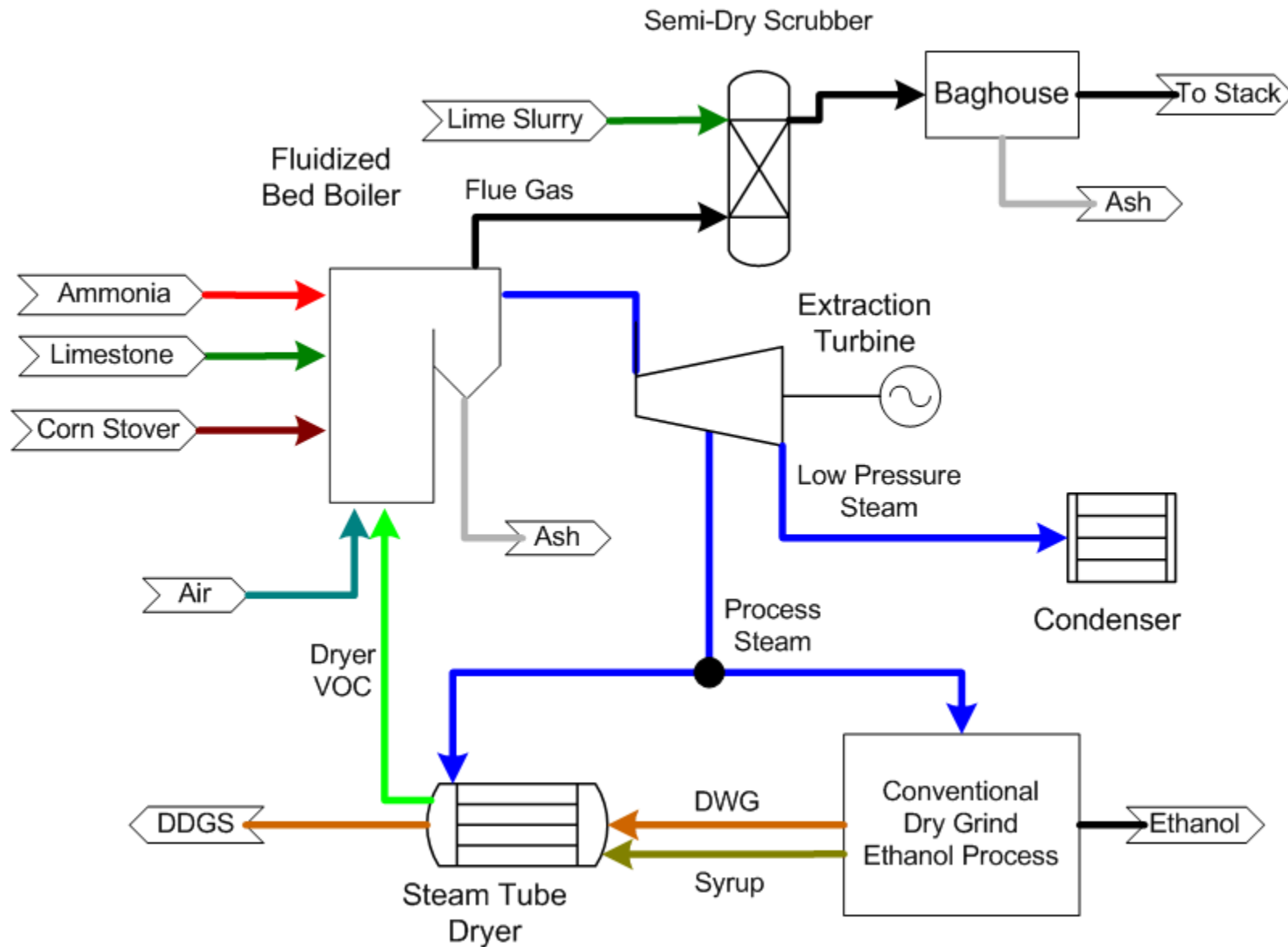

Corn Stover & Syrup Combustion, Level 2: CHP

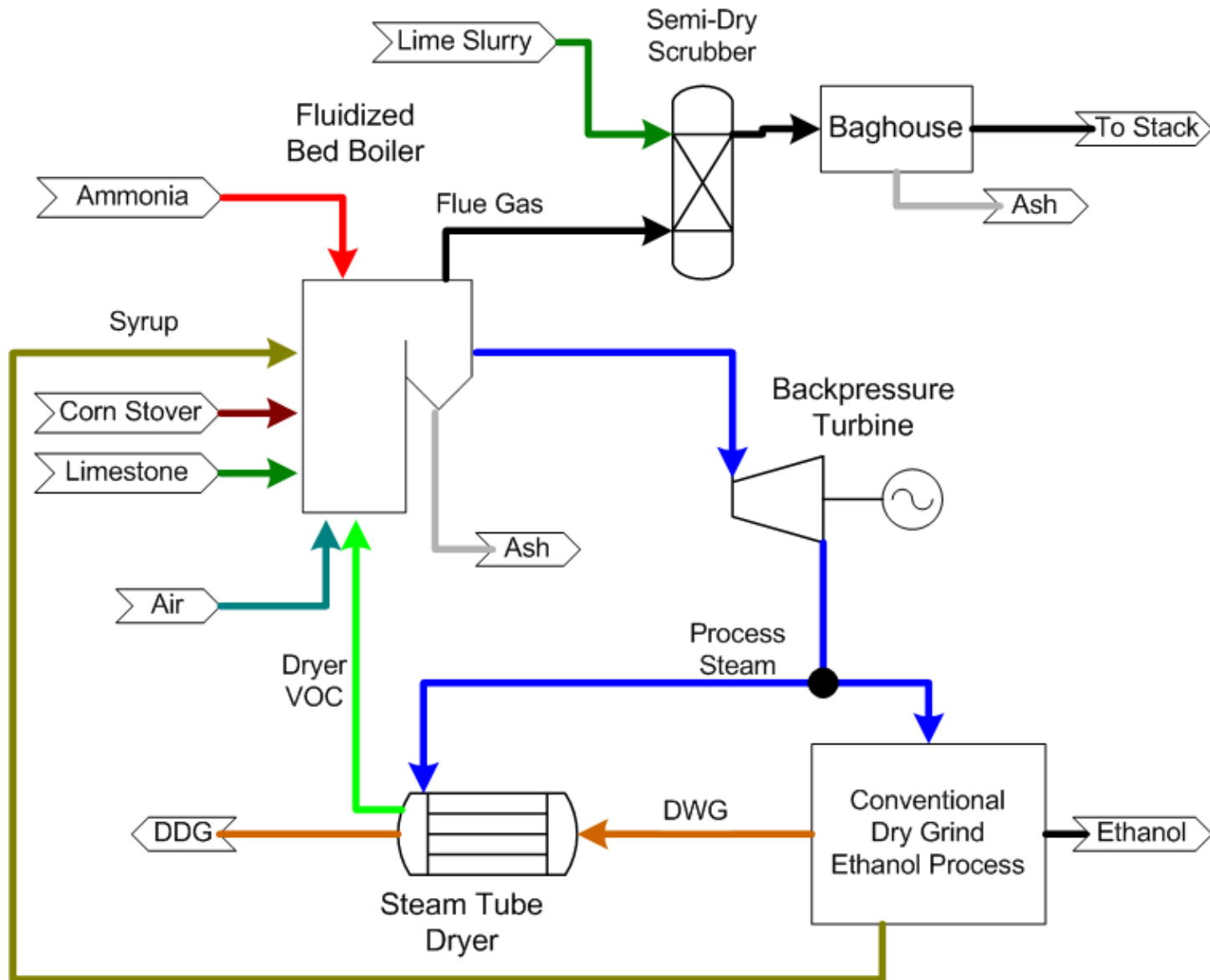

DDGS Gasification, Level 2: CHP

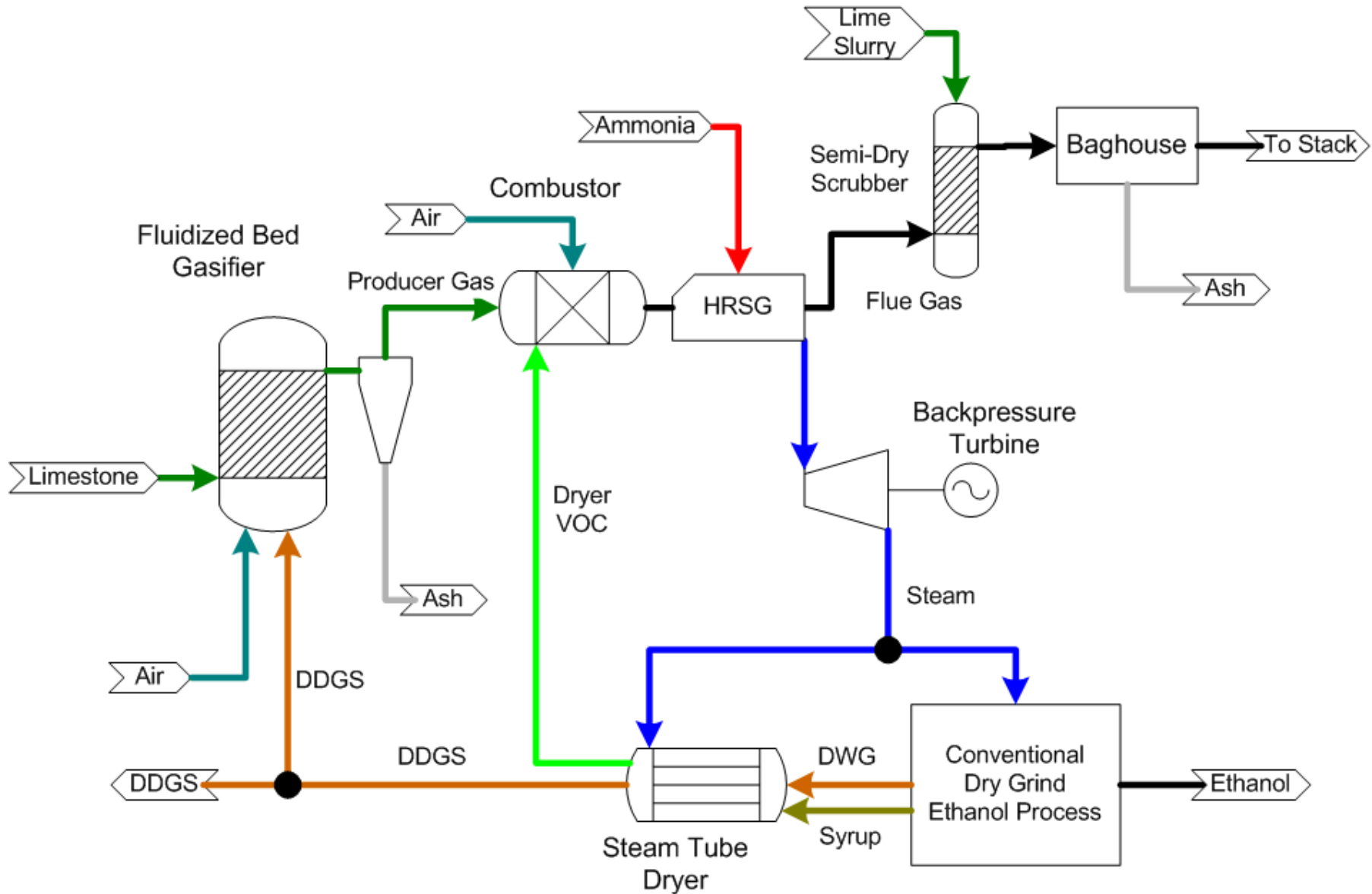

Biomass Fuel Energy Input (HHV) 50 MMgal/yr

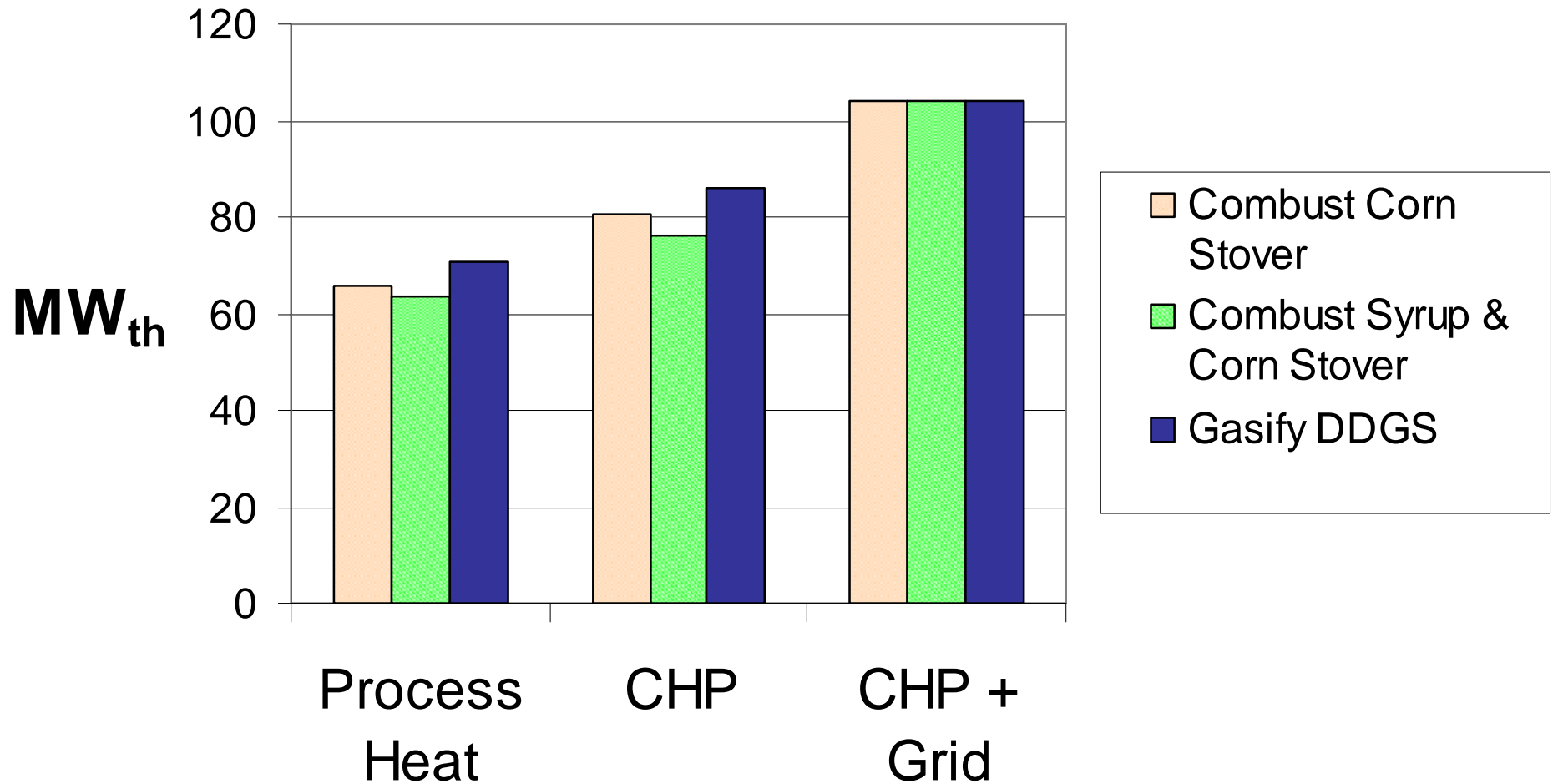

Biomass Fuel Use (Wet Basis) 50 MMgal/yr

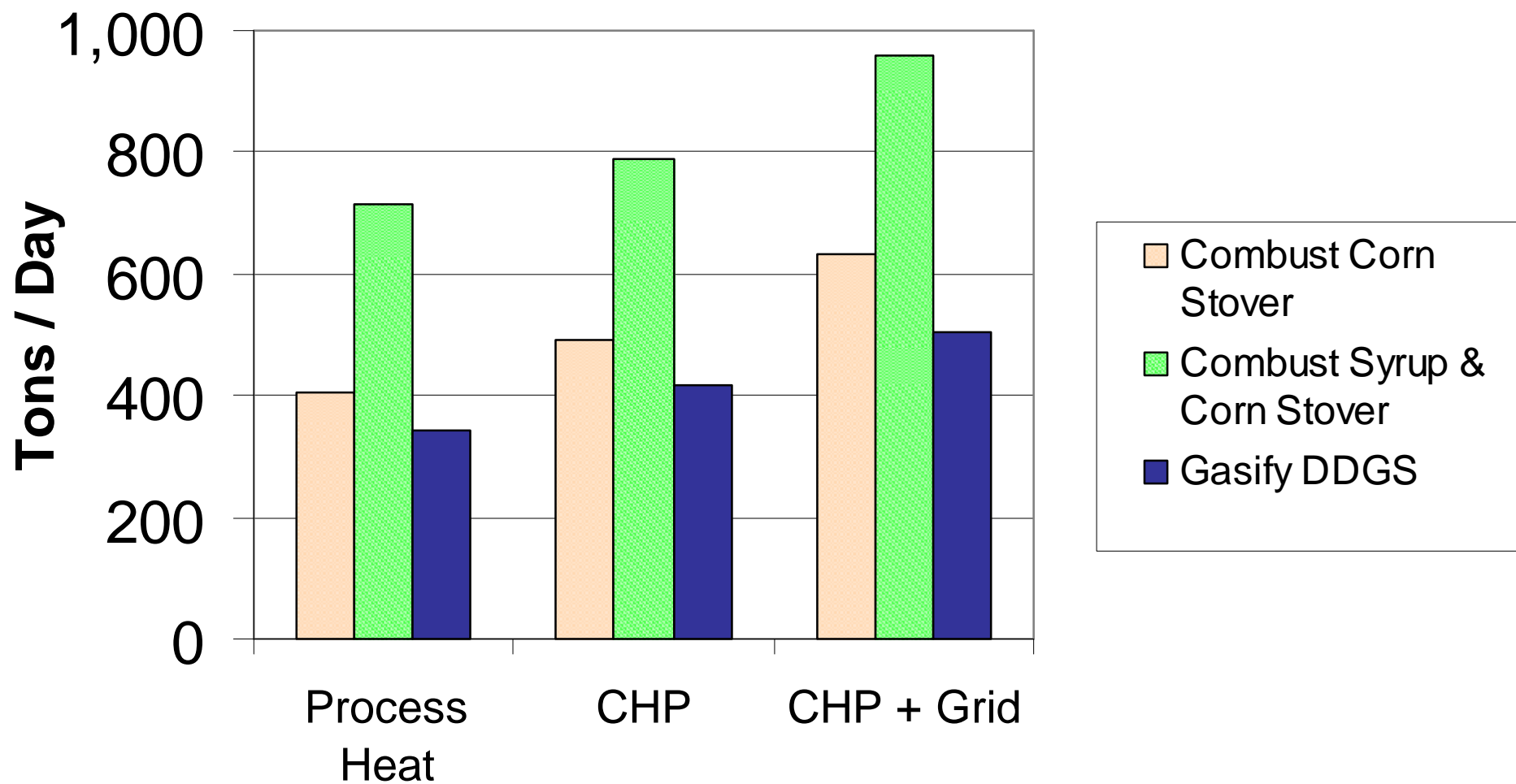

Syrup & Corn Stover Combustion: Fuel Energy Input Rate Contribution (HHV) 50 MMgal/yr

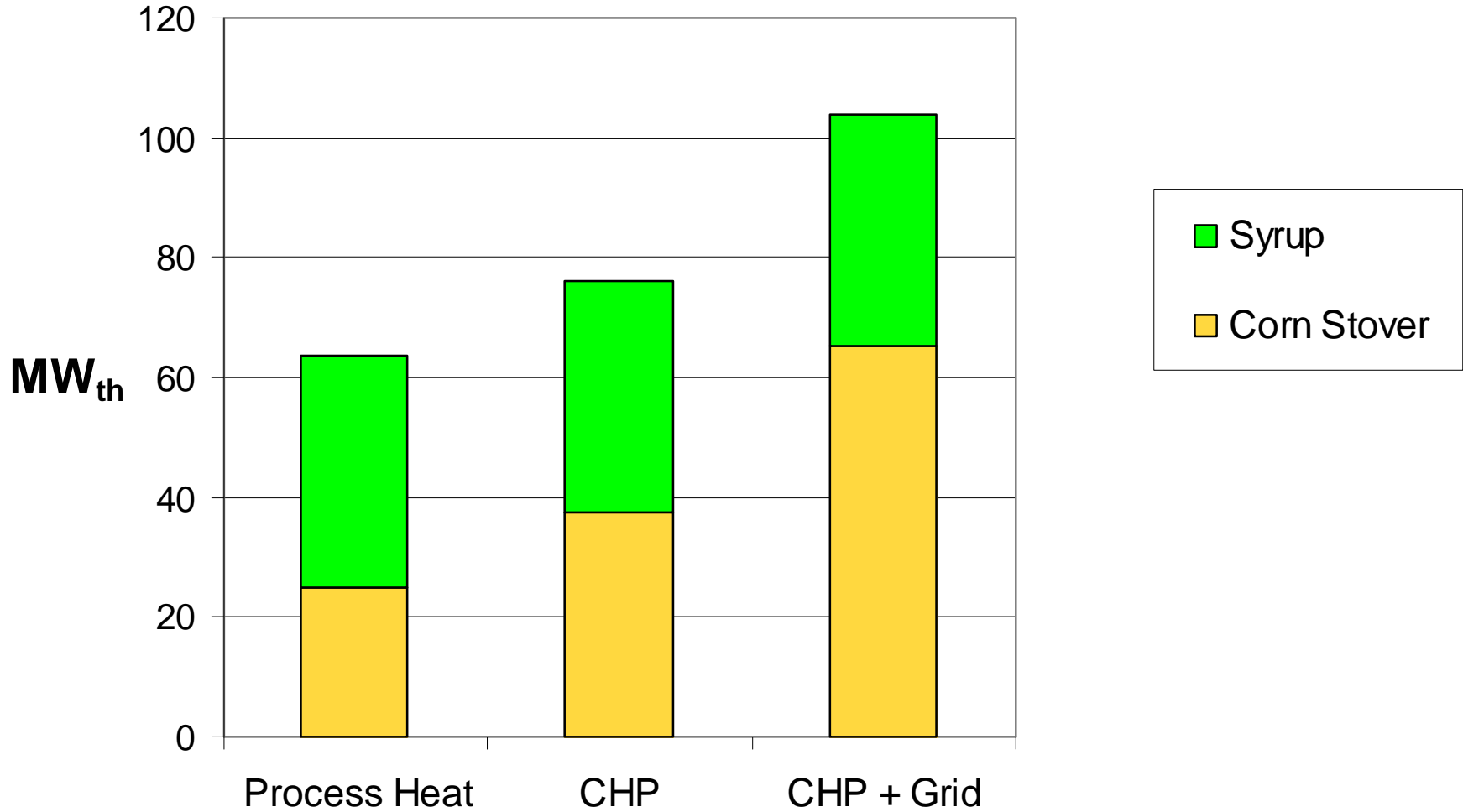

Syrup & Corn Stover Combustion: Fuel Use (Wet Basis) 50 MMgal/yr

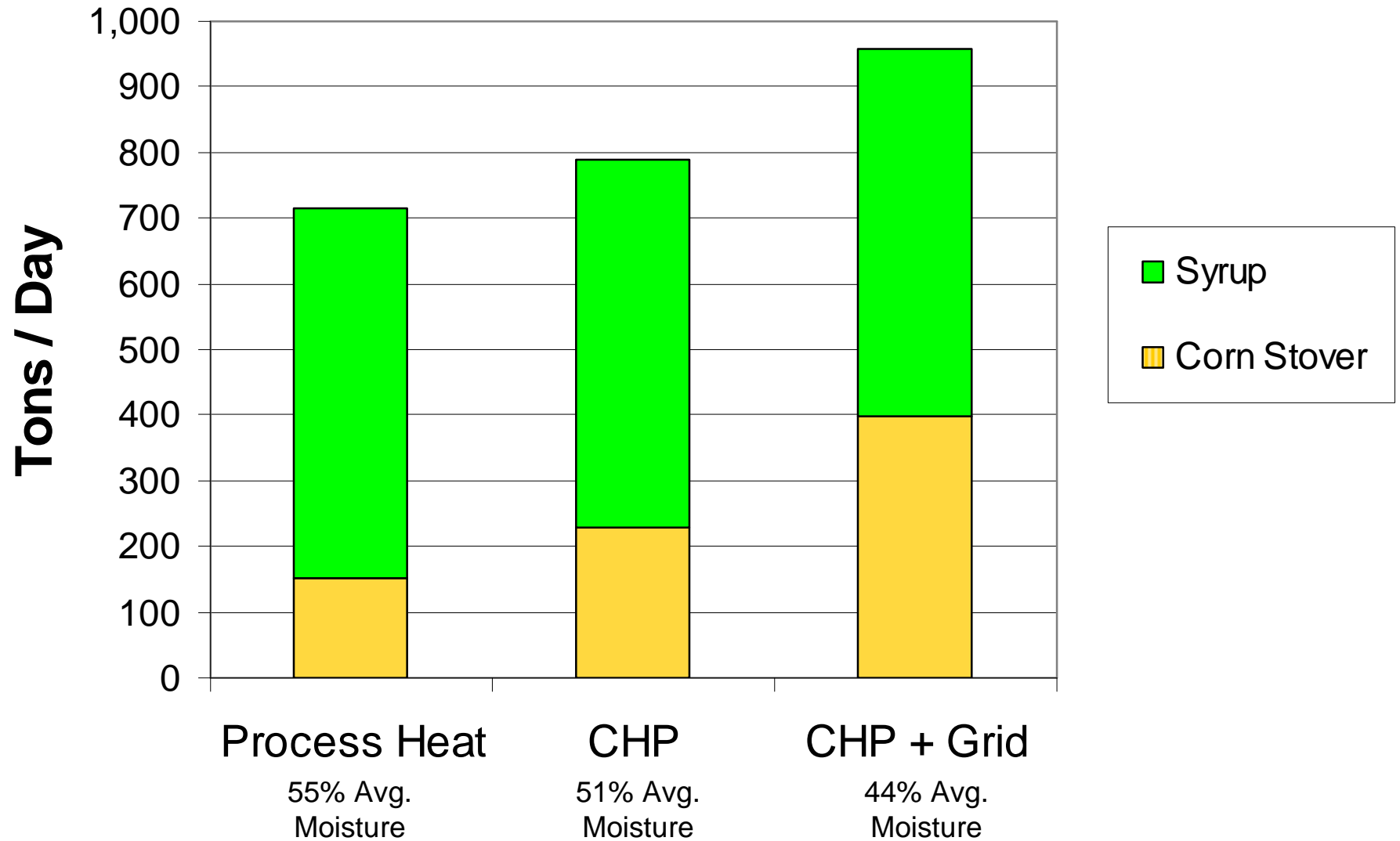

Corn Stover Combustion: Electricity Balance

50 MMga/yr

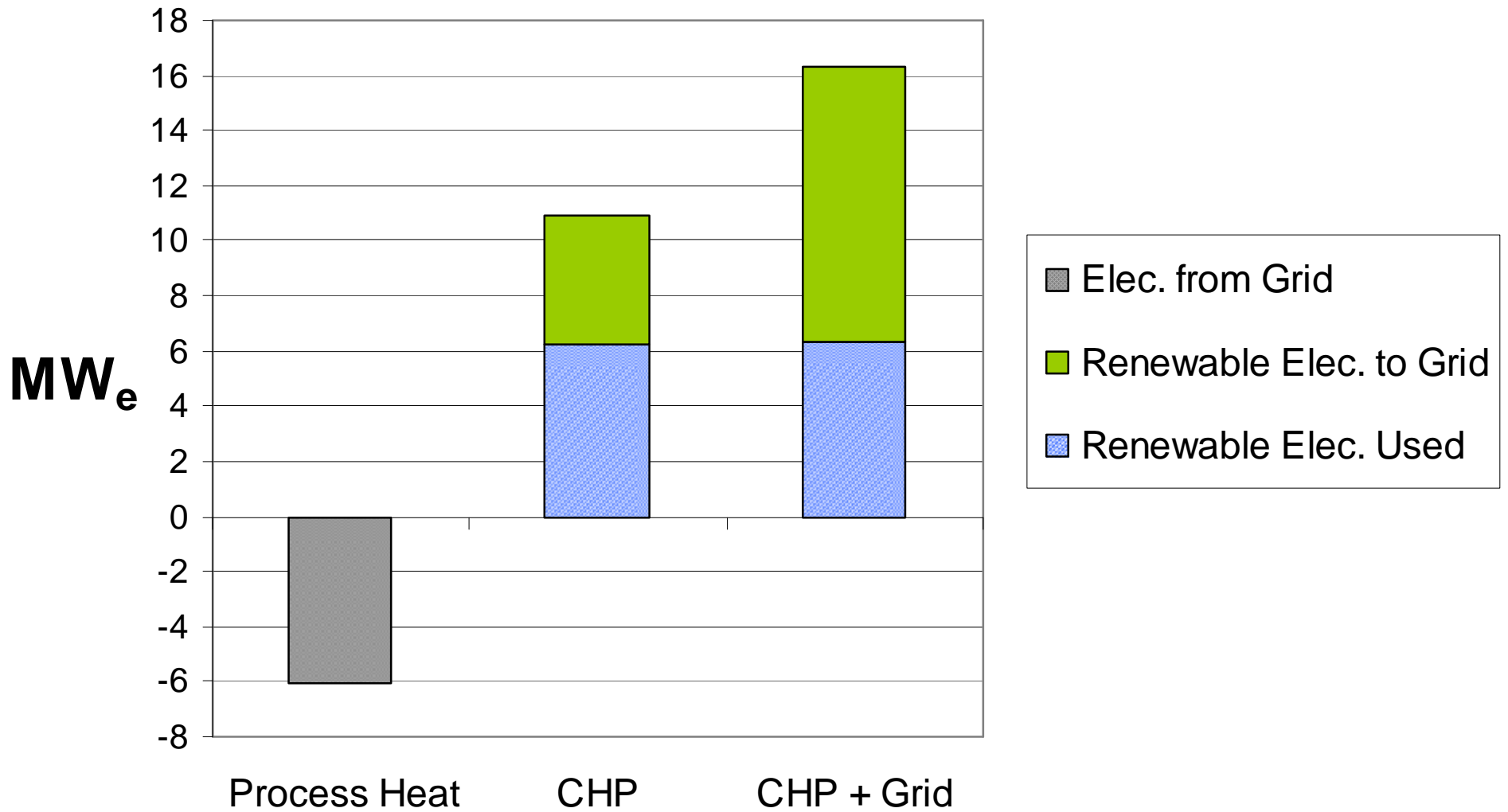

Syrup & Corn Stover Combustion: Electricity Balance, 50 MMgal/yr

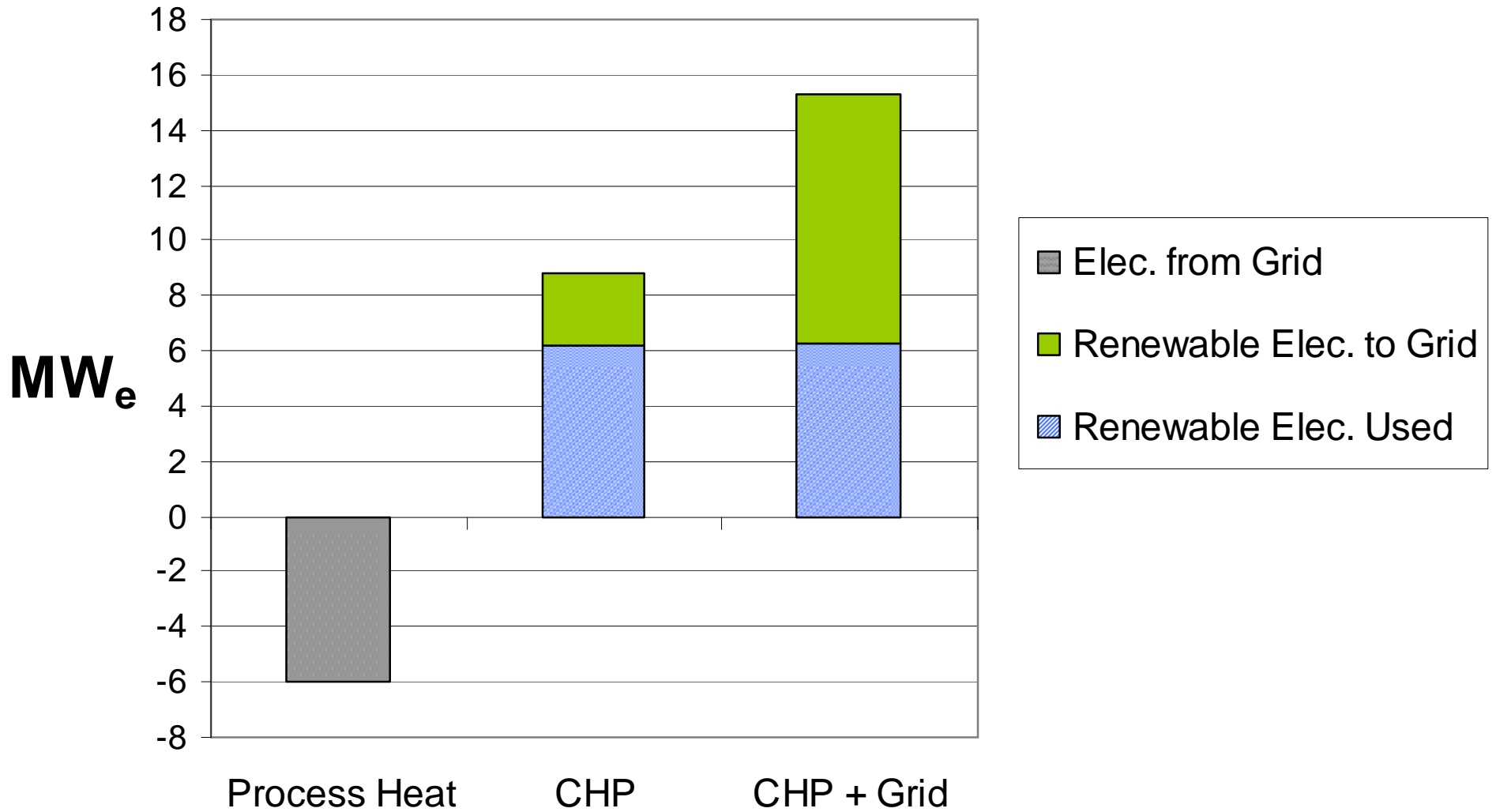

DDGS Gasification: Electricity Balance 50 MMga/yr

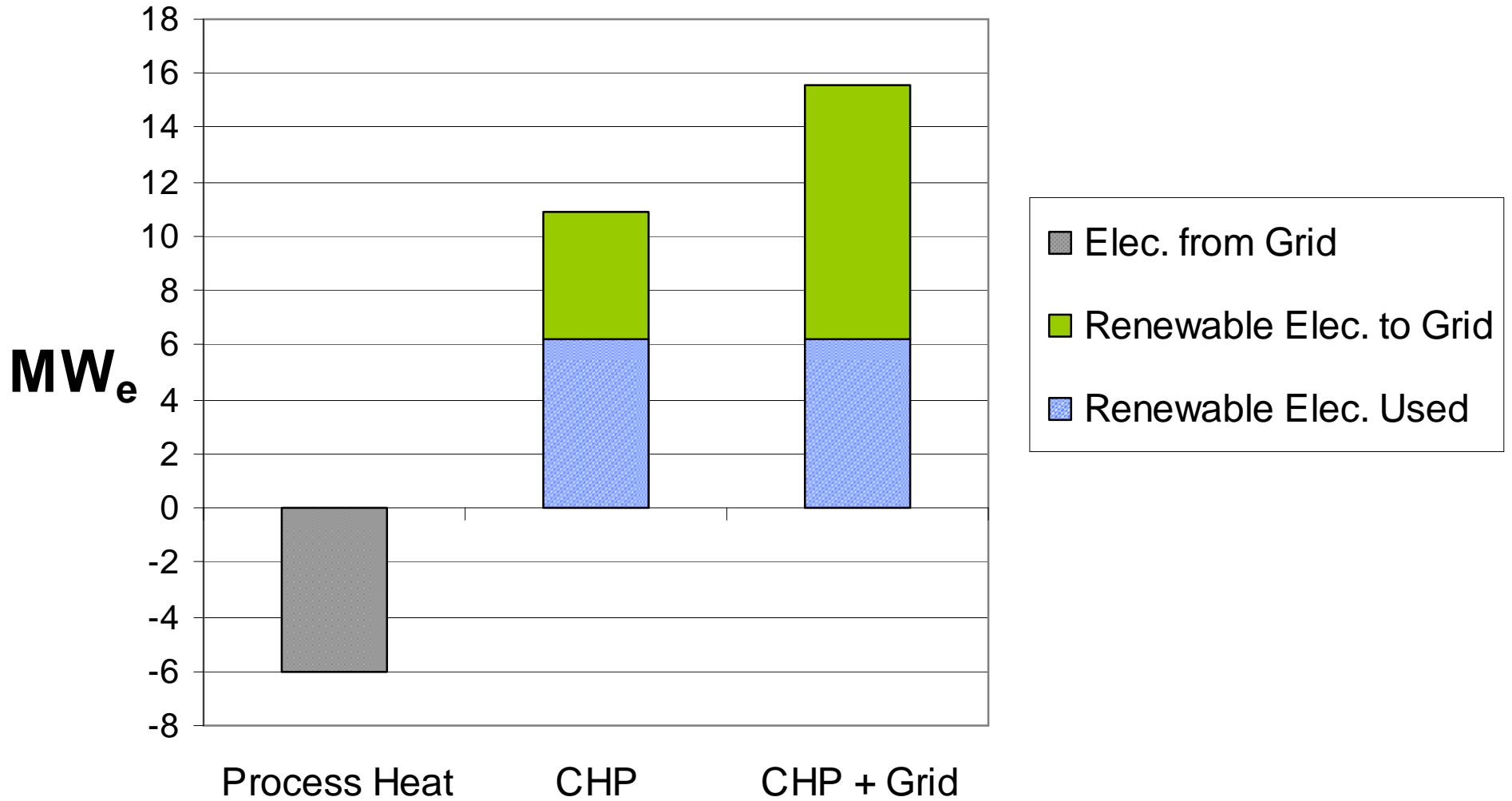

Results

Corn Stover Combustion: 50 MMGal/yr				
		1. Proc. Heat	2. CHP	3. CHP + Grid
Fuel Energy Input	MWth	66	81	104
Power Gen. (Gross)	MWe	0	10.9	16.3
Power to Grid	MWe	(6.0)	4.7	10.0
Power Gen. Efficiency		-	13.5%	15.7%
Thermal Efficiency		77%	76%	64%

(all valued based on fuel HHV)

Results

Syrup & Corn Stover Combustion: 50 MMGal/yr				
		1. Proc. Heat	2. CHP	3. CHP + Grid
Fuel Energy Input	MWth	64	76	104
Power Gen. (Gross)	MWe	0	8.8	15.3
Power to Grid	MWe	(6.0)	2.6	9.0
Power Gen. Efficiency		-	11.6%	14.7%
Thermal Efficiency		64%	65%	54%

(all valued based on fuel HHV)

Results

DDGS Gasification: 50 MMGal/yr				
		1. Proc. Heat	2. CHP	3. CHP + Grid
Fuel Energy Input	MWth	71	86	104
Power Gen. (Gross)	MWe	0	10.9	15.6
Power to Grid	MWe	(6.0)	4.7	9.3
Power Gen. Efficiency		-	12.7%	15.0%
Thermal Efficiency		72%	72%	64%

(all valued based on fuel HHV)

NO_x Emissions After Control Technology

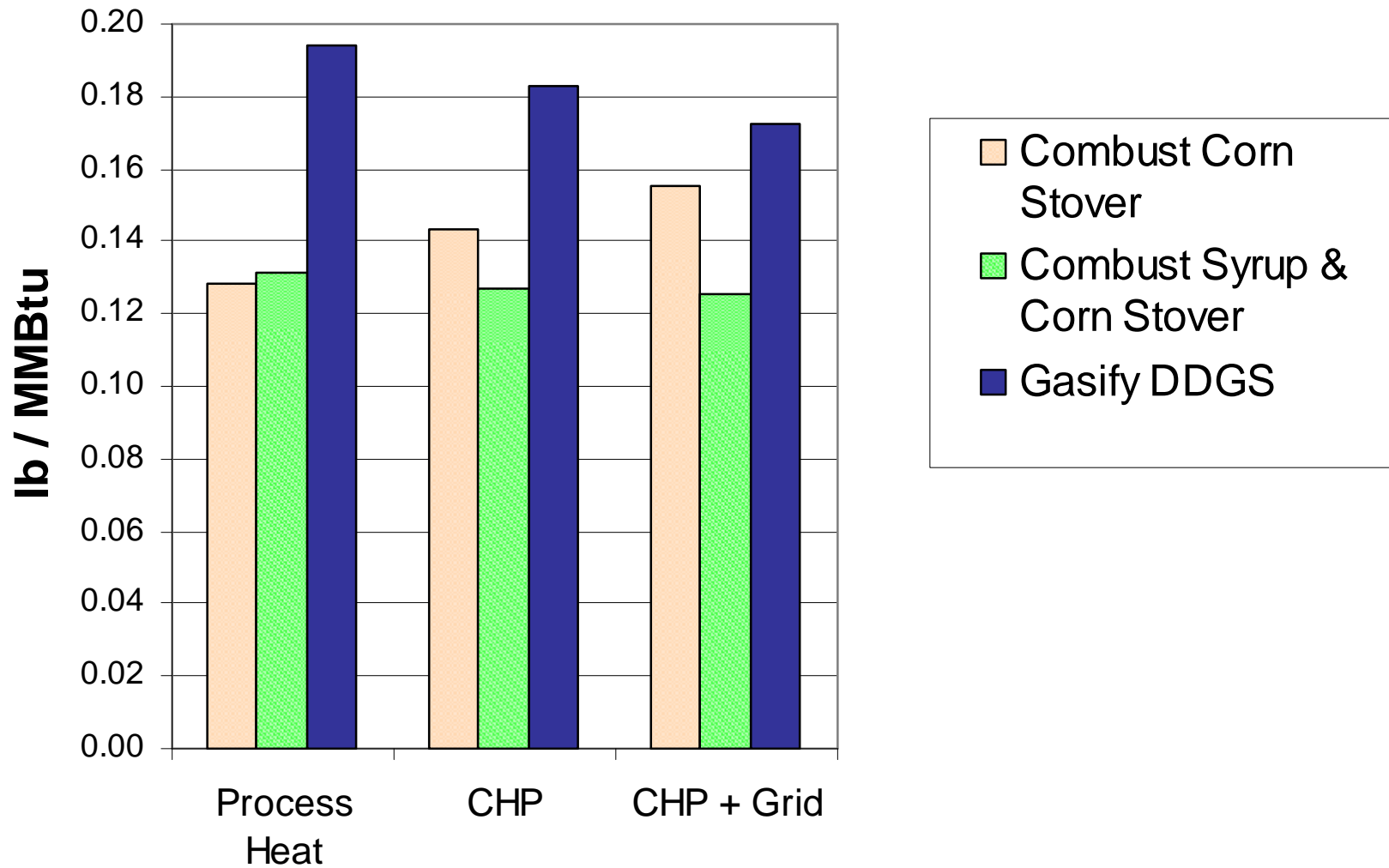

NO_x Emissions

After Control Technology
50 MMgal/yr

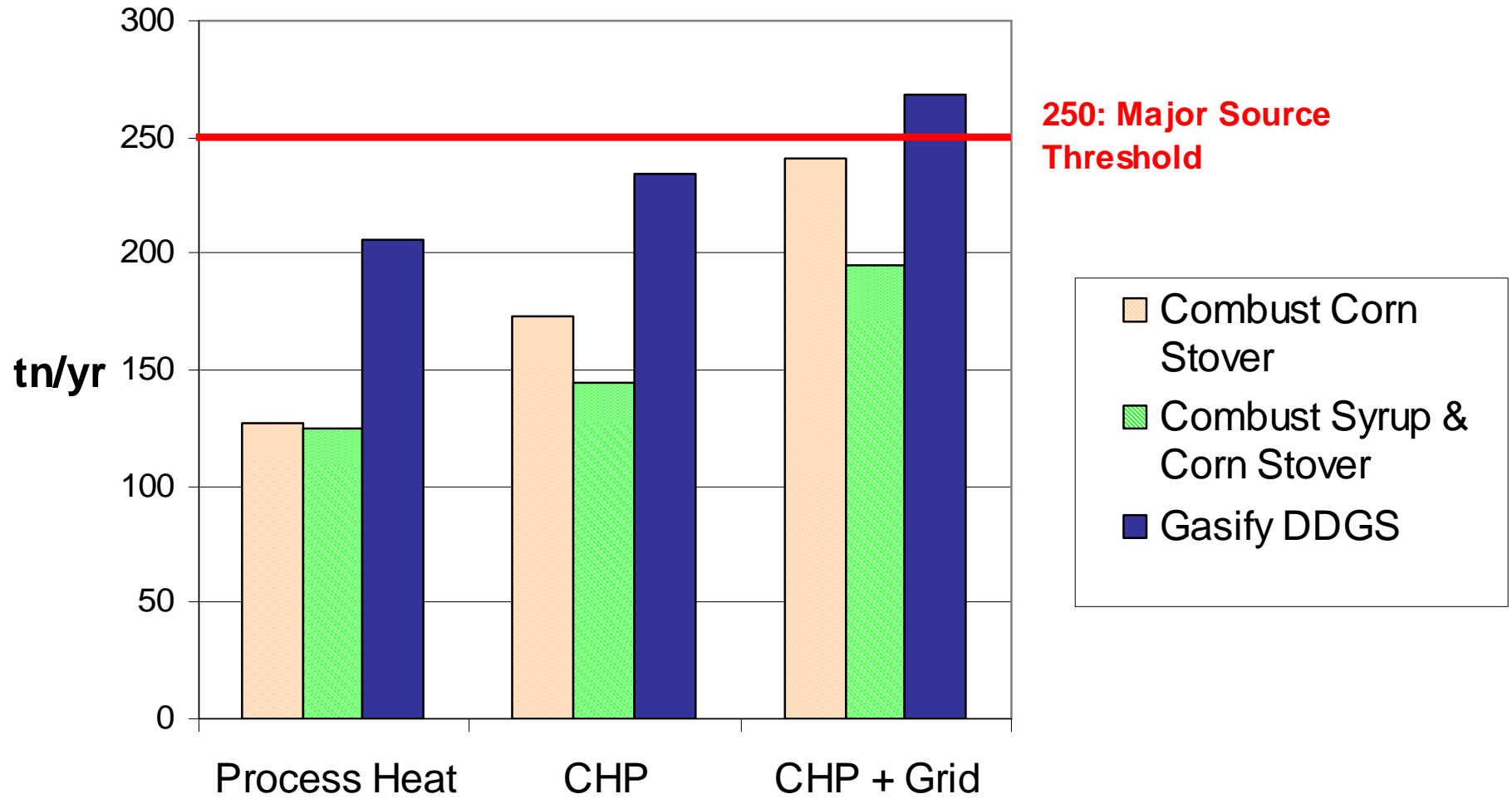

**250: Major Source
Threshold**

- Combust Corn Stover
- Combust Syrup & Corn Stover
- Gasify DDGS

SO₂ Emissions

After Control Technology

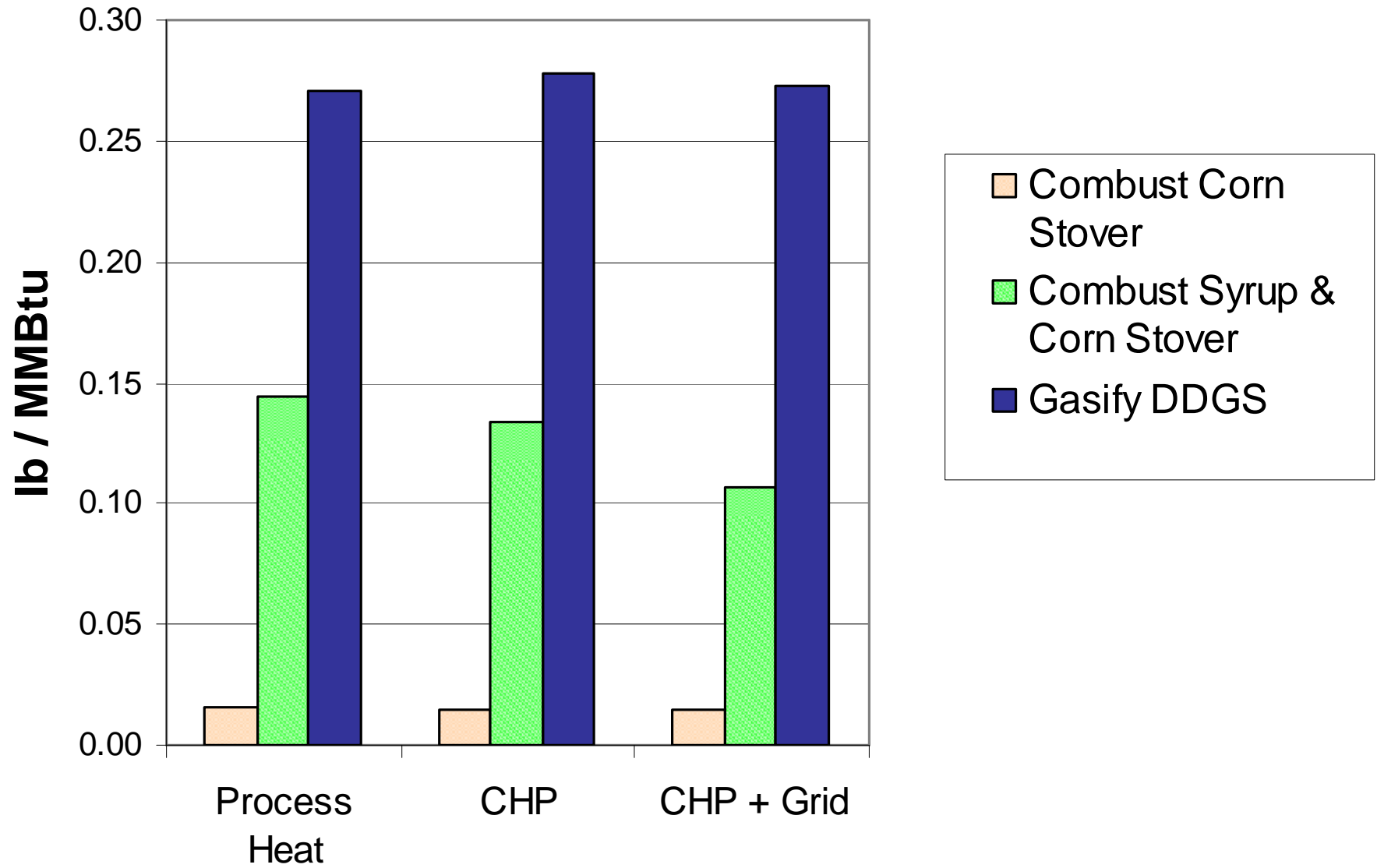

SO_x Emissions

After Control Technology

50 MMgal/yr

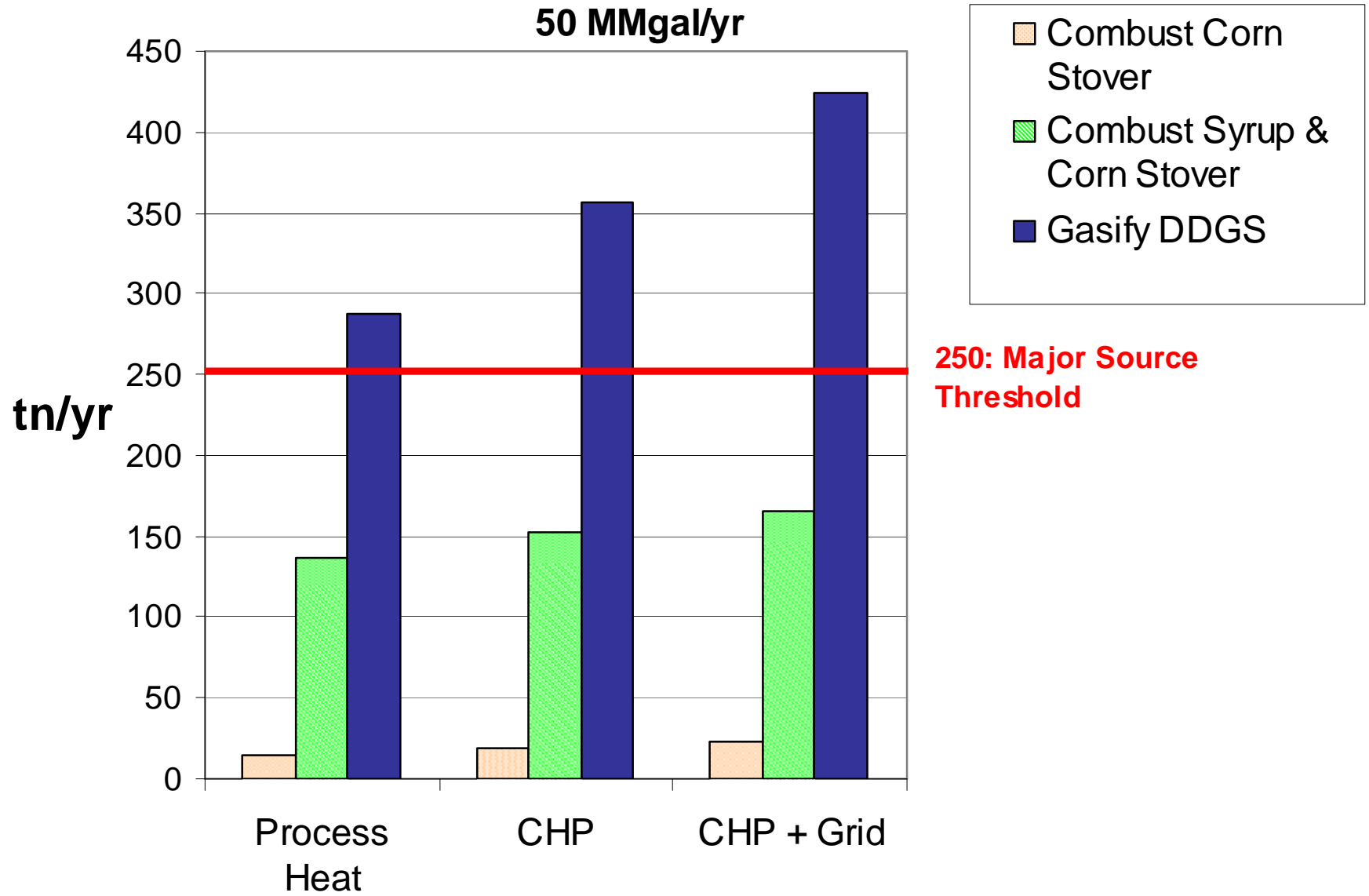

HCL Emissions After Control Technology

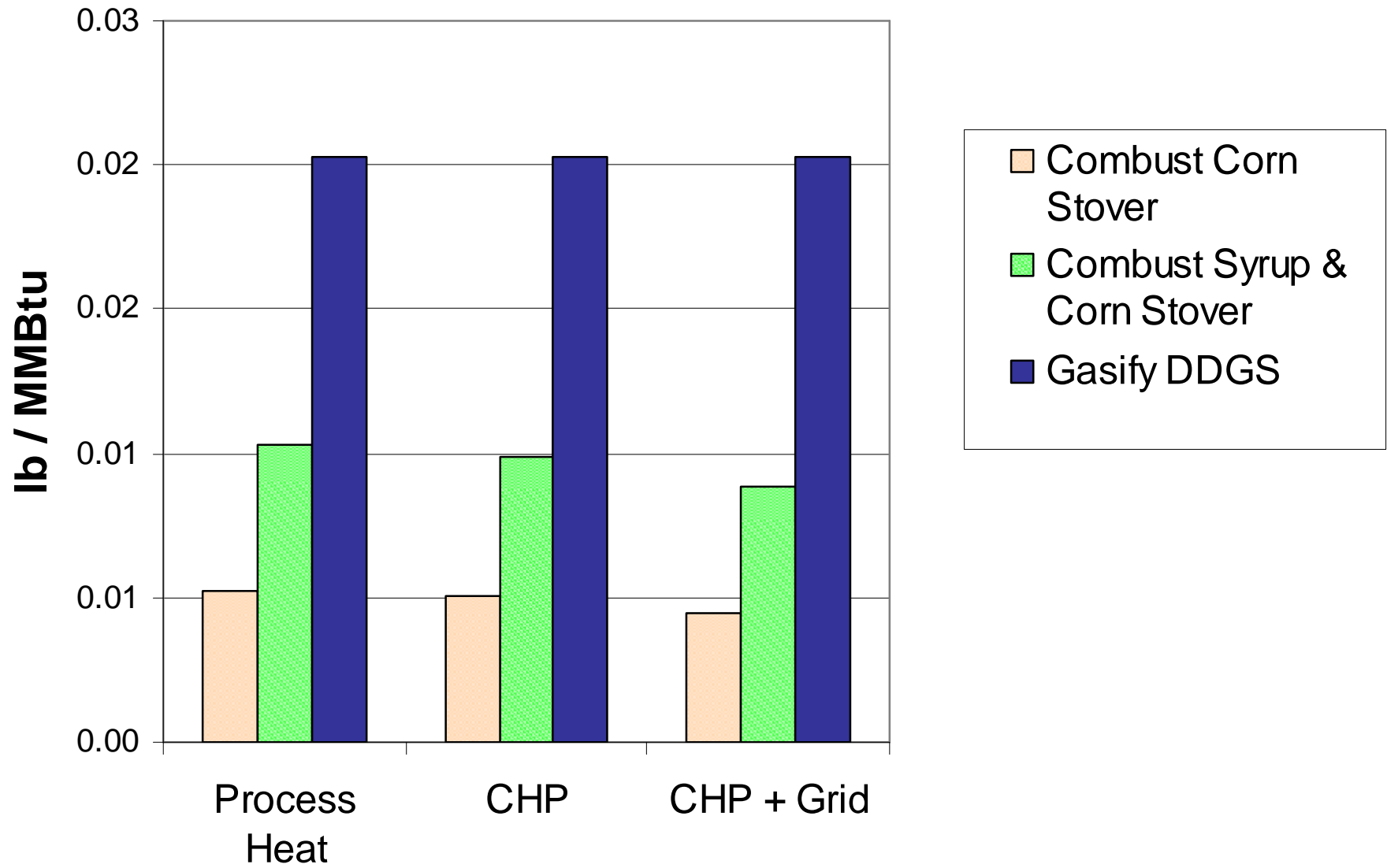

HCL Emissions

After Control Technology

50 MMgal/yr

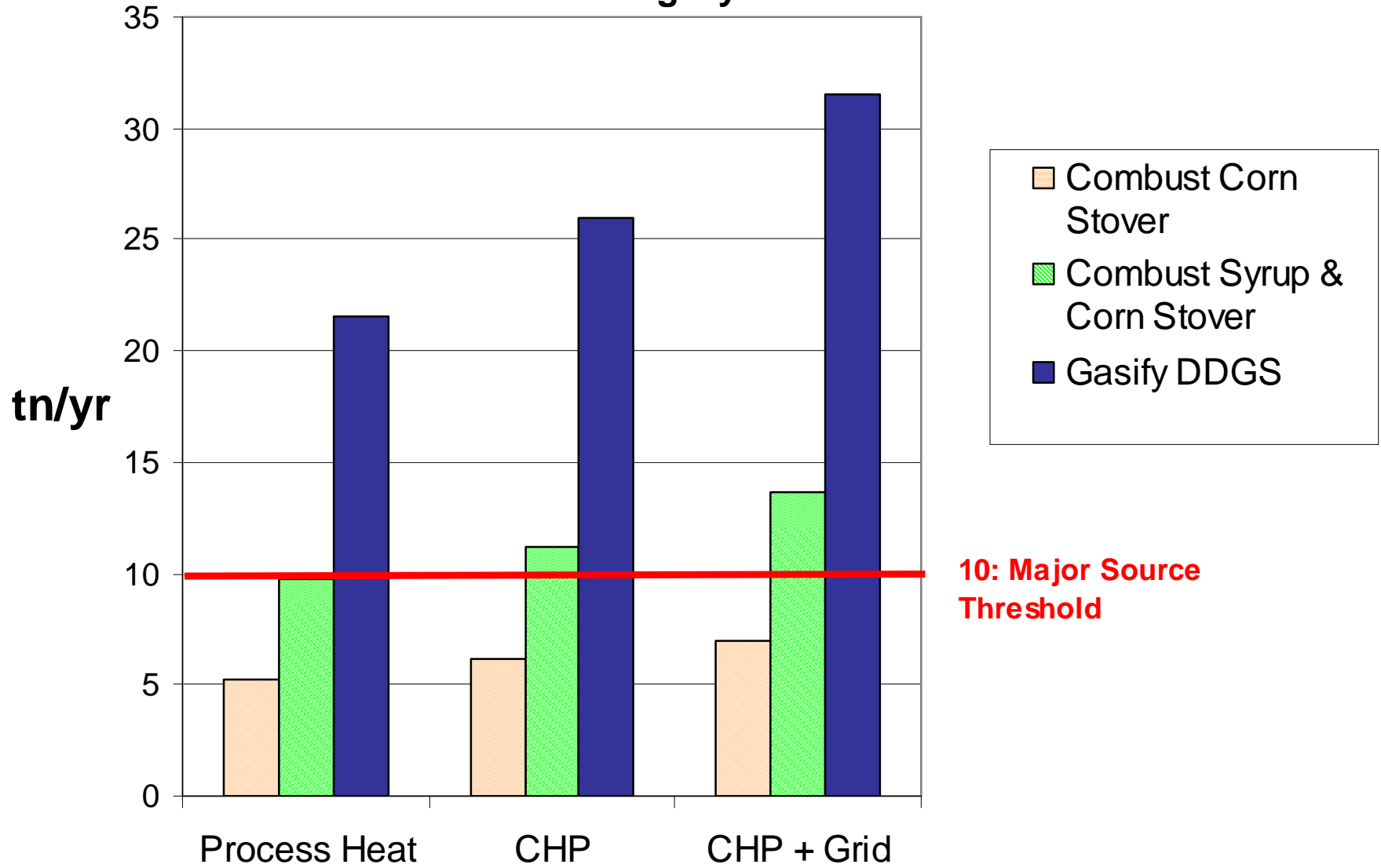

Renewable Energy Ratio (LHV)

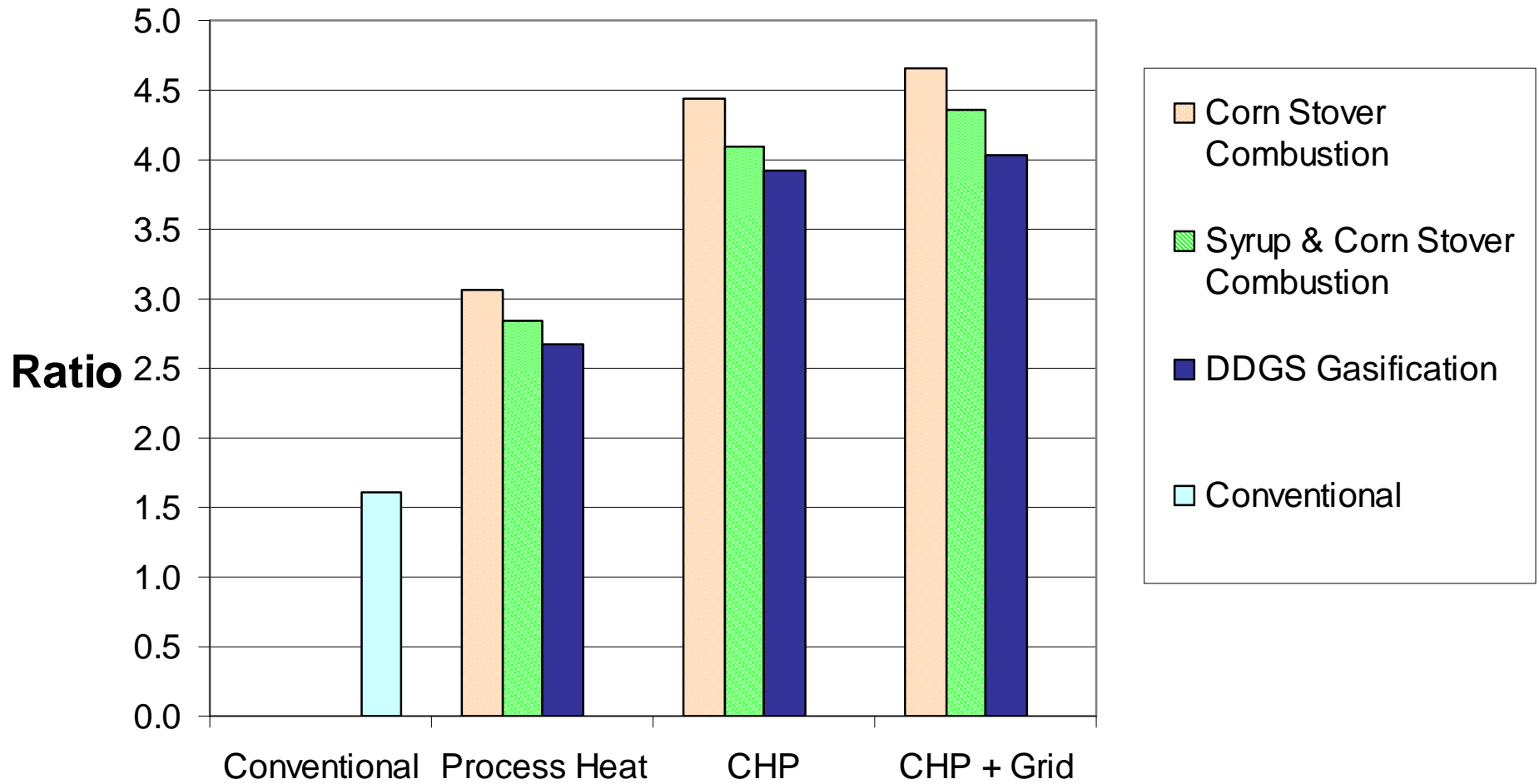

Conclusions

- n Using biomass to fuel ethanol plants can significantly improve the renewable energy balance
 - n Ethanol plants have more than enough co-product material to provide all the plant heat and power needs
 - n Emissions will be an important issue, especially with DDGS
 - n The economics will determine feasibility
-

Future Analysis

- n Integrated Gasification Combined Cycle
 - n Increased electricity production efficiency
 - n Superheated steam dryers
 - n Higher efficiency
 - n All dryer exhaust steam is condensed
-